

INSTRUCTION MANUAL

for

Model VC-210-B (Brass)

DIAPHRAGM CONTROL VALVE

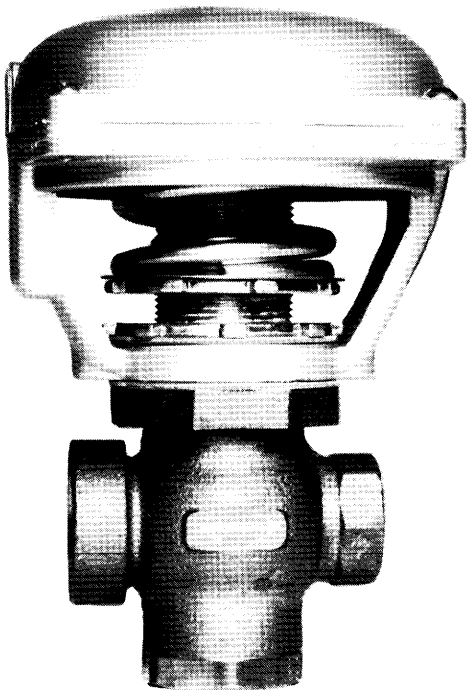

Model No. _____

Serial No. _____

RIPD Order No. _____

NOTE TO INSTALLER: Before installing, read instructions carefully and record model number and serial number. After installing, give this bulletin to operating personnel or see that it is filed for future reference.

Robertshaw

Robertshaw Industrial Products Division
1602 Mustang Drive
Maryville, Tennessee 37801

Telephone: (865) 981-3100
Fax: (865) 981-3168

INSTRUCTION MANUAL
P-5000 (Rev. A)

TABLE OF CONTENTS

SPECIFICATIONS	3
Inner Valve Construction	3
Flow Coefficients, C_v	4
Maximum Allowable Pressure Drop	4
Dimensions, Shipping Weights	5
OPERATION	6
INSTALLATION	6
A. Valve Piping	6
B. Air Piping to Valve	6
C. Packing	6
ADJUSTMENTS	7
MAINTENANCE	7
A. General	7
B. Replacement of Diaphragm	7
C. Replacement of Spring	8
D. Replacement of Primary Bellows Seal	8
E. Replacement of Primary Bellows Seal or Valve Plug — BJ, BJR, BL, BLR	8
F. Replacement of Primary Bellows Seal or Valve Plug— BN, 3-Way	8
G. Replacement of Primary Bellows Seal or Valve Plug, BH	9
ORDERING INFORMATION	9
PARTS LISTS	
BJ, BJR, BL, BLR	10
BN, BH	11
Parts List Tables	12, 13

SPECIFICATIONS

ACTUATOR ASSEMBLY

Nominal size: 10 sq. in.

Action: Direct-Acting — Increasing air pressure moves stem downward.

Nominal Travel: 3/8" (9.5 mm)

Spring Range: 3-15 psi (0.2 - 1.0 bar) standard.

Other ranges available (See Table II).

Maximum Air Pressure: 30 psi (2.0 bar)

Maximum Ambient Temperature: 180° F. (82° C.)

Air Connection: 1/8" NPT, female

Materials of Construction:

Diaphragm — Molded EPDM

Housing and Frame — Die-cast aluminum, iridite finished for corrosion resistance, painted bronzeless gold.

Spring — Zinc plated alloy steel.

VALVE ASSEMBLY

ACTION:

Direct (provides air-to-close action with actuator)
Reverse (provides air-to-open action with actuator)
Three-way (top port normally closed)

Valve Body Assembly Ratings:

100 psi for brass bodies @ 350° F.
(6.9 bar @ 177° C.)

End Connections: Female NPT inlet and outlet.

Seat Ring: 316 stainless steel, replaceable in 2-way body; integral brass seats in 3-way body.

Materials of Construction:

Body — Brass ASTM B584 for 2-way and 3-way valves.

Trim — 316 stainless steel in 2-way valves;
Brass in 3-way valves.

Primary Packing — Nickel plated beryllium copper bellows in brass bodies.

Secondary Packing — Buna-N O-Ring

INNER VALVE CONSTRUCTION

These illustrations represent the 3-way and direct-acting 2-way body styles.

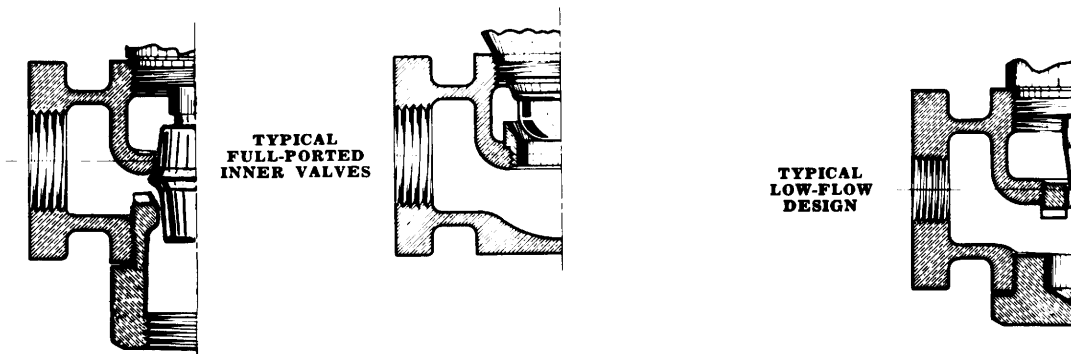

3-Way Style BN
Brass Plug on
Integral Brass Seat

Styles BJ, BL
Teflon O-Ring Seating

Style BH
Top Guided

TABLE I
2-Way Valves

Valve Style		Valve Body Material	Flow Characteristic	Seating Style	Trim Material	Valve Size, In.	C _v	
Direct Acting	Reverse Acting						DA	RA
BJ	BJR	Brass	Quick Opening	Teflon* O-Ring	316	1/2	4.0	4.0
					Stainless Steel	3/4	8.0	8.0
						1	9.0	8.5
BL	BLR	Brass	Equal Percentage	Teflon* O-Ring	316	1/2	2.0	2.0
					Stainless Steel	3/4	7.5	8.0
						1	8.5	8.5
BH	—	Brass	Linear	Stainless Steel Needle Plug	316 Stainless Steel	1/2	.03	
							0.6	

3-WAY VALVES

BN	Brass	Linear	Brass Plug on Integral Brass Seat	Brass	1/2	2.2
					3/4	4.6
					1	9.0

* Registered TM of DuPont.

MAXIMUM ALLOWABLE PRESSURE DROP

When the control valve is required to close off against the full upstream pressure with 0 psig on the downstream side of the valve, the upstream pressure should be considered as the maximum pressure drop. The tabulated maximum pressure drops are for throttling service only. Where rapid cycling or on-off type service is the application, the pressure differential across a VC-210 control valve should not exceed 50 psi (3.45 bar). In any case the upstream pressure should not exceed 100 psi (6.89 bar). The tabulated ratings are based on a 3-15 psi (0.2 – 1.0 bar) signal to the diaphragm.

TABLE II

Nominal Valve Size	Bench Test Spring Ranges ¹						
	Air-to-Close		Air-to-Open			3-Way	
	3-12 psi* (0.2-0.8 bar)	3-7 psi (0.2-0.5 bar)	6-15 psi* (0.4-1.0 bar)	8-15 psi (0.55-1.0 bar)	11-15 psi (0.75-1.0 bar)	5-14 psi* (0.3-0.9 bar)	9-13 psi (0.6-0.9 bar)
Max. Allowable Pressure Drop							
1/2	90	100	100	100	100	60	100
3/4	50	100	100	100	100	35	80
1	30	90	50	80	100	20	40

*Standard springs ¹Bench test with 0 psi in valve body.

DIMENSIONS, SHIPPING WEIGHTS

(All dimensions in Inches and millimeters)

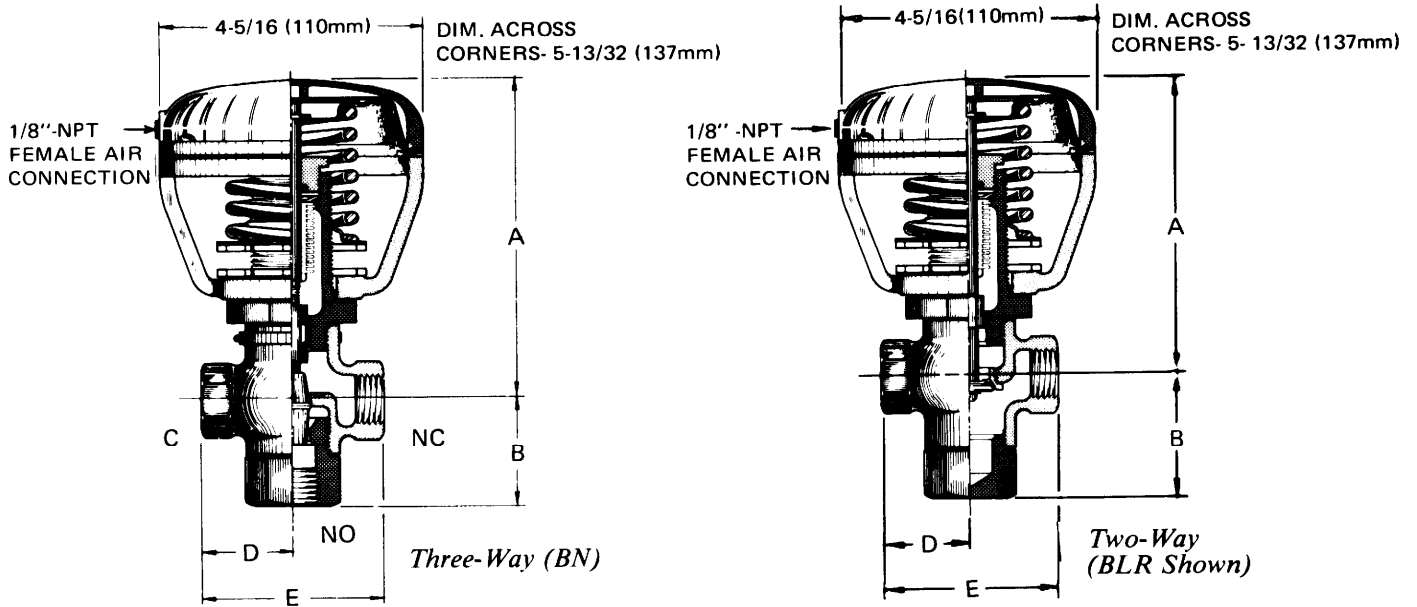

TABLE III

Valve Style	Pattern	Material	Dimension	Valve Size, Inches (millimeters)		
				1/2	3/4	1
BJ	Two-way	Brass	A	5 (127)	5-1/4 (133)	5-1/4 (133)
BJR			B	1-19/32 (40.5)	1-15/16 (49.2)	1-15/16 (49.2)
BL			D	1-1/2 (38.1)	2 (50.8)	2 (50.8)
BLR			E	3 (76.2)	4 (102)	4 (102)
BN	Three-Way	Brass	A	5-5/16 (135)	5-5/16 (135)	5-13/16 (148)
			B	1-3/4 (44.5)	2-5/32 (54.8)	3-7/32 (81.8)
			D	1-1/2 (38.1)	2 (50.8)	2-1/2 (63.5)
			E	3 (76.2)	4 (102)	5 (127)
BH	Two-Way	Brass	A	5-3/8 (137)		
			B	1-3/4 (44.5)		
			D	1-1/2 (38.1)		
			E	3 (76.2)		
All Styles			Shipping Wgt., Lbs. (Kg)	4-3/4 (2.1)	6-1/4 (2.8)	9 (4.1)

OPERATION

Model VC-210 Diaphragm Control Valves are compact, ruggedly constructed and especially designed for the control of water, steam, gas, vacuum, etc. Valves are single seated, bellows sealed to prevent stem leakage, and may be selected to have the valve action, seating materials, and flow characteristics needed for the most critical control applications.

The pneumatic actuator consists of a molded 10 sq. in. EPDM diaphragm enclosed in a die-cast aluminum housing and frame. The readily accessible spring adjusting nut provides easy field adjustment of the starting point within the selected spring range. Synthane gaskets located between the valve bonnet and the actuator frame reduce heat transfer to the diaphragm.

INSTALLATION

These instructions apply for all VC-210 series Diaphragm Control Valves. All operate in the same manner and differ only in body style and valve plug construction.

A. VALVE PIPING

The size of a diaphragm control valve is computed to give full throttling action under certain specific conditions of flow and pressure drop. To ensure obtaining maximum performance, the control valve should not be placed in the main line adjacent to elbows, bends or plug cocks where abnormal velocities may occur. The size of the main line is usually one or two nominal sizes larger than the size of the control valve. When it is desired to use plug cocks for shut-off valves, they should be the same size as the main line and not the size of the control valve.

If it is desirable to have continuous operation when necessary to inspect or replace any of the parts, install a conventional three-valve bypass around the control valve.

When installing the valve in the line, observe the following precautions:

1. Install a pipeline strainer just ahead of the valve.
2. Allow sufficient clearances so that the valve may be easily serviced if necessary.
3. A minimum clearance of 3½" (88.9 mm) must be allowed between the extreme top of the control valve and the nearest obstruction. This permits removal of actuator frame and parts required to replace packing bellows.
4. Use a good grade of pipe compound and apply only above the second or third male threads in moderate amounts.
5. Make sure the flow through the valve body is in the direction indicated by the arrow on the side of the body.

Inspect all parts of the control valve for any foreign material that may have collected during shipment. Clean and blow out all pipe lines to remove pipe scale and chips.

B. AIR PIPING TO VALVE

Run 1/4" or 3/8" tube or pipe from the connection on the diaphragm case to the outlet fitting of the instrument or pilot controller. To avoid excessive delay in response, it is recommended that the distance should be less than 150 ft. (46 meters) from the instrument to valve. If excessive distances are necessary, one or more booster relays, Robertshaw CR 100-A1, may be used to speed the response.

C. PACKING (Figure 2)

A seamless Sylphon® bellows provides the primary packing.

A secondary O-Ring seal affords protection in the event of rupture of the primary packing bellows.

Primary Packing:

Bronze Bodies — Nickel plated beryllium copper seamless Sylphon® bellows.

Secondary Packing:

Bronze Bodies — Buna-N O-Rings.

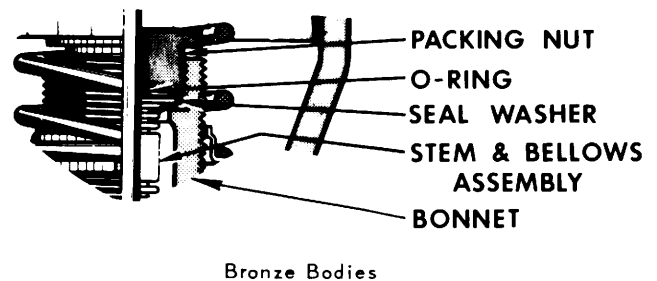

Figure 2 - PACKING

ADJUSTMENTS

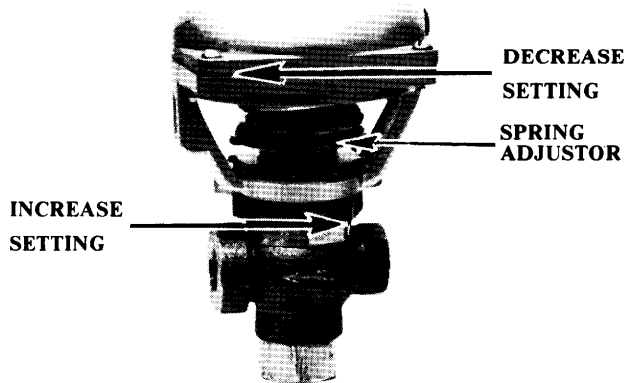

Figure 3 - ADJUSTMENTS

Every valve should be checked on or before startup for correct stroke, freedom from friction, correct location, and proper flow direction through the body.

In all cases of trouble, always check first the air lines and fittings for leaks and make sure you have the correct assembly for the desired action.

For successful performance of this equipment, the valve stem must move freely in response to air pressure change on the diaphragm. If this type of action is not being obtained, check the following:

1. *Valve Plug* — Examine the valve guides for “scoring” as a result of foreign material or misalignment.
2. *Diaphragm* — A diaphragm that is no longer pliable or is ruptured must be replaced.

If the above parts are performing correctly, any trouble that may be encountered will likely be found in the controller or instrument.

When the valve is completely installed and connected to the instrument or controller, open the manual downstream valve and close the bypass valve. Slowly open the upstream manual control valve. Allow the controller sufficient time to assume normal operation before checking the controlled pressure.

The size of the diaphragm control valve is computed to give full throttling action.

The diaphragm control valve is shipped from the factory with the spring adjustment properly set for the operating conditions specified on your order.

Under actual service conditions, pressure drops can differ. For this reason, the spring may have to be adjusted in order to compensate for the pressure drop so that full valve travel may be obtained over the diaphragm pressure range. This adjustment is accomplished by turning the spring adjuster to the right to increase spring compression and to the left to decrease spring compression. (See Figure 3).

MAINTENANCE

A. GENERAL

The actuator and valve are shipped completely assembled with all adjustments made. However, step-by-step procedures are given in the following paragraphs should it be necessary to disassemble the unit for inspection or maintenance.

B. REPLACEMENT OF DIAPHRAGM (Figure 4)

1. Remove air pressure.
2. Turn the spring adjuster to the left to relieve spring tension.
3. Remove screws holding upper diaphragm case to the yoke. Lift off the diaphragm case which then allows the diaphragm to be removed.

NOTE: When installing diaphragm be sure the word “UP” is in the UP position.

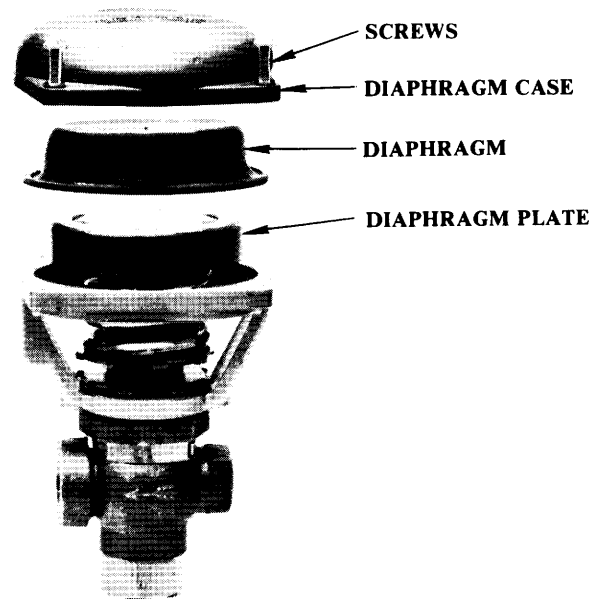

Figure 4 - REPLACEMENT OF DIAPHRAGM

C. REPLACEMENT OF SPRING (Figure 5)

1. Turn spring adjuster to the left to relieve spring tension.
2. Remove screws, diaphragm case, diaphragm and diaphragm plate.
3. Remove E-Ring and spring seat.
4. Spring can now be removed and new one installed.
5. Reassemble in reverse order.

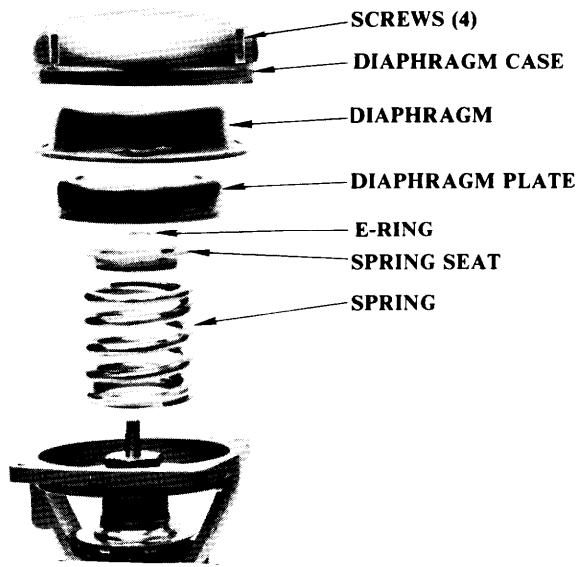

Figure 5 — REPLACEMENT OF SPRING

D. REPLACEMENT OF PRIMARY BELLOWS SEAL

If valve stem leakage is encountered, primary bellows seal and O-Ring must be replaced. When the primary bellows seal is to be replaced it is recommended that a complete group of parts be used made up of E-Ring, O-Ring, seal washer and stem and bellows assembly. When performing these operations, care should be exercised to prevent damage to the highly finished packing and seating surfaces.

E. REPLACEMENT OF PRIMARY BELLOWS SEAL OR VALVE PLUG (Figure 7)

BJ, BJR, BL and BLR Valves

REPLACEMENT OF VALVE PLUG:

1. Turn spring adjuster to the left to release spring tension.
2. *Direct-Acting* — Remove bonnet from valve (valve plug will be removed with the bonnet as a single unit). Remove screw, washer, plug, O-Ring and retainer.
3. Replace with new parts and replace bonnet on the valve.

4. *Reverse-Acting* — Remove bottom cap. Add air to diaphragm case so that plug is pushed down and away from seat. Remove screw, washer, retainer, O-Ring and plug.
5. Replace with new parts. Remove air to diaphragm case and replace bottom cap.

REPLACEMENT OF PRIMARY BELLOWS SEAL:

1. Turn spring adjuster to the left to release spring tension.
2. Complete step 2 above (direct-acting) or step 4 (reverse-acting) under "Replacement of Valve Plug."
3. Remove screws, diaphragm case, diaphragm and diaphragm plate.
4. Remove E-Ring, spring seat and spring.
5. Remove packing nut, O-Ring and seal washer.
6. Remove defective stem and bellows assembly and replace with new assembly.
7. Place seal washer on bellows head.
8. Lubricate O-Ring and install over stem flush against the seal washer.
9. Install packing nut so that bellows head is seated firmly against the bonnet shoulder.
10. Replace spring, spring seat and E-Ring.
11. Replace diaphragm plate, diaphragm and diaphragm case.
12. Install four screws to hold diaphragm case to yoke. The diaphragm chamber must be leak-tight, so care must be taken to seat the diaphragm properly in the case groove.
13. *Direct-Acting* — Replace retainer, O-Ring, plug, washer and screw. Replace bonnet on valve.
14. *Reverse-Acting* — Add air to diaphragm case. Replace retainer, O-Ring, plug, washer and screw. Remove air and replace bottom cap.
15. Adjust spring adjuster to obtain proper spring load.

F. REPLACEMENT OF PRIMARY BELLOWS SEAL OR VALVE PLUG (Figure 9)

BN Valves – 3 Way

1. Turn spring adjuster to the left to release spring tension.
2. Remove screws, diaphragm case, diaphragm and diaphragm plate.
3. Remove E-Ring, spring seat and spring.
4. Remove packing nut, O-Ring and seal washer.
5. Turn stem and bellows assembly counterclockwise until disengaged from anti-torque bushing and remove. Replace if the assembly is defective.
6. Remove bottom cap and valve plug unit. (Valve plug unit consists of valve plug, anti-torque bushing and on larger valves, bushing.) Replace if the unit is badly worn.
7. Turn stem and bellows assembly clockwise until engaged approximately 3/8" (9.5 mm) in anti-torque bushing.
8. Place seal washer on bellows head.
9. Lubricate O-Ring and install over stem flush

- against the seal washer.
10. Install packing nut loosely so that stem and bellows assembly may be rotated.
 11. With valve plug on seat (valve stem up) adjust stem, Figure 6, until dimension A is .781" (19.84 mm). After this adjustment is made, tighten packing nut so that bellows head is seated firmly against the bonnet shoulder.
 12. Replace spring, spring seat and E-Ring.
 13. Replace diaphragm plate, diaphragm and diaphragm case.
 14. Install four screws to hold diaphragm case to yoke. The diaphragm chamber must be leak-tight, so care must be taken to seat the diaphragm properly in the case groove.
 15. Adjust spring adjustor to obtain proper spring load.

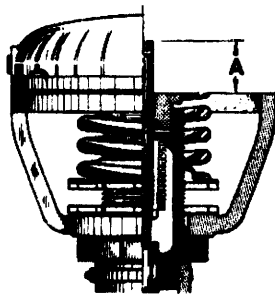

Figure 6 – SPRING ADJUSTMENT

G. REPLACEMENT OF PRIMARY BELLOWS SEAL OR VALVE PLUG (Figure 10)

BH Valves

1. Turn spring adjustor to the left to release spring tension.
2. Remove bonnet from valve.
3. Remove screws, diaphragm case, diaphragm and diaphragm plate.
4. Remove E-Ring, spring seat and spring.
5. Remove packing nut, O-Ring and seal washer.
6. Remove stem and bellows assembly and valve plug.
7. Turn stem and bellows assembly counterclockwise until disengaged from valve plug. Replace defective part(s). Engage stem in valve plug approximately 3/8" (9.5 mm).
8. Place seal washer on bellows head.
9. Lubricate O-Ring and install over stem flush against the seal washer.
10. Install packing nut loosely so that stem and bellows assembly may be rotated.
11. Replace bonnet on valve.
12. With valve plug on seat (valve stem down), adjust stem until dimension A, Figure 6, from top of yoke to top of stem is .515" (13.08 mm). After this adjustment is made, tighten packing nut so that bellows head is seated firmly against the bonnet shoulder.
13. Replace spring, spring seat and E-Ring.
14. Replace diaphragm plate, diaphragm and diaphragm case.
15. Install four screws to hold diaphragm case to yoke. The diaphragm chamber must be leak-tight, so care must be taken to seat the diaphragm properly in the case groove.
16. Adjust spring adjustor to obtain proper spring load.

PARTS LIST

ORDERING INFORMATION (PARTS)

From the illustrations appearing on the following pages choose the one corresponding to your valve style and identify parts required. Using detail numbers appearing alongside the part name, find the production part numbers for valve size and complete valve assembly number in Parts List Tables.

Please specify:

1. Complete model number.
2. Serial Number
3. Valve size
4. Detail number and part description
5. Production part number and figure number.

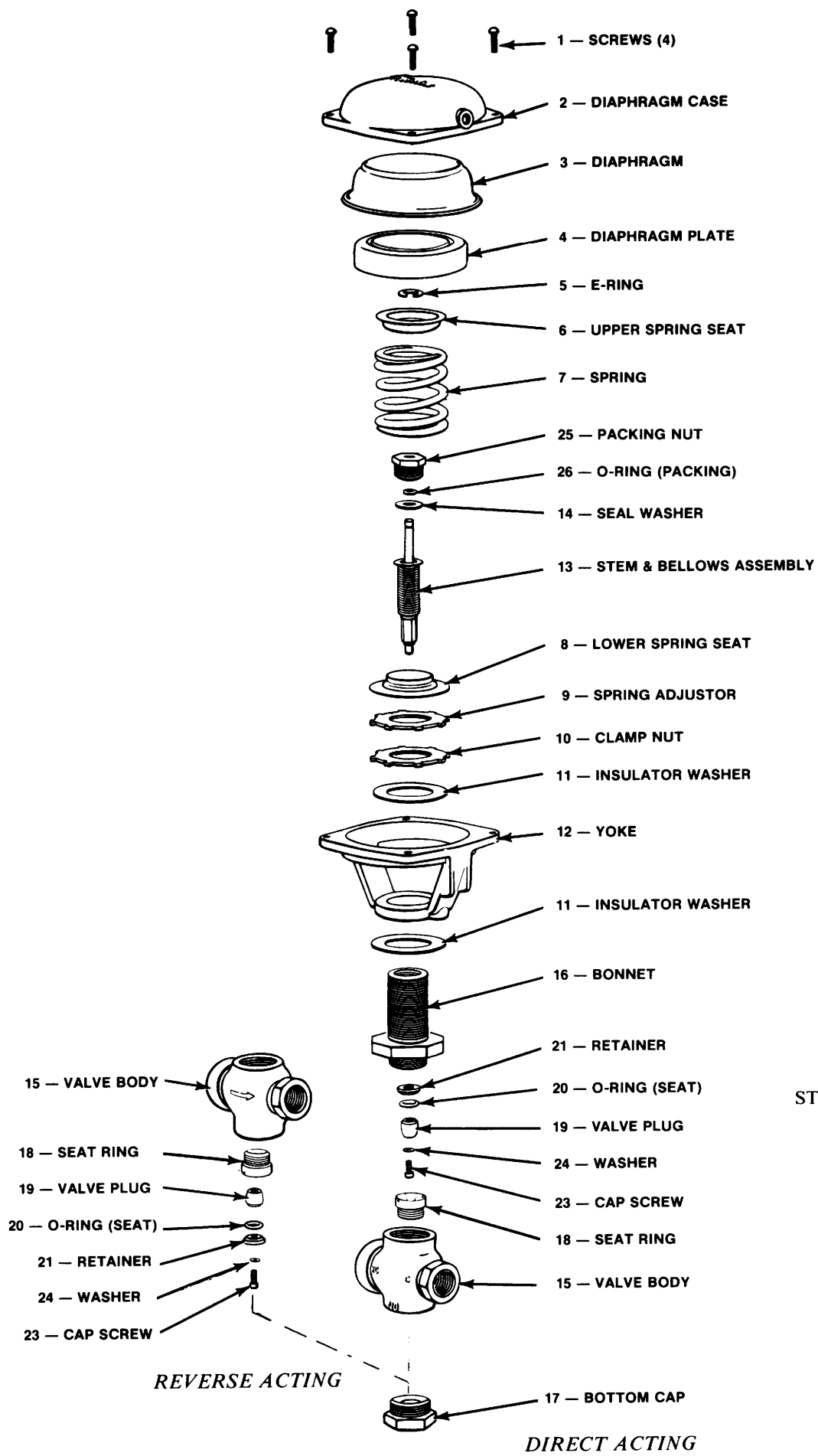

FIGURE 7
 STYLES BJ, BJR,
 BL, BLR

(See Parts List
 Tabulations,
 Page 12)

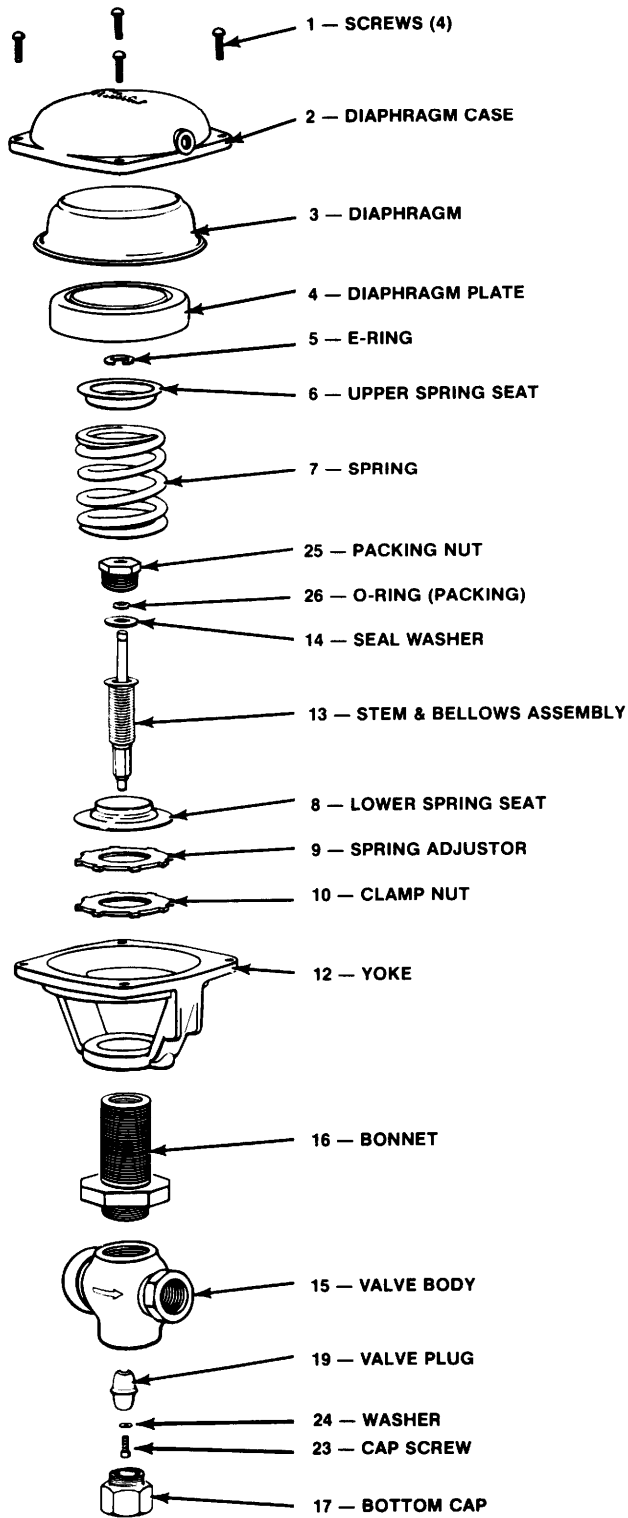

Figure 9
STYLE BN, THREE-WAY

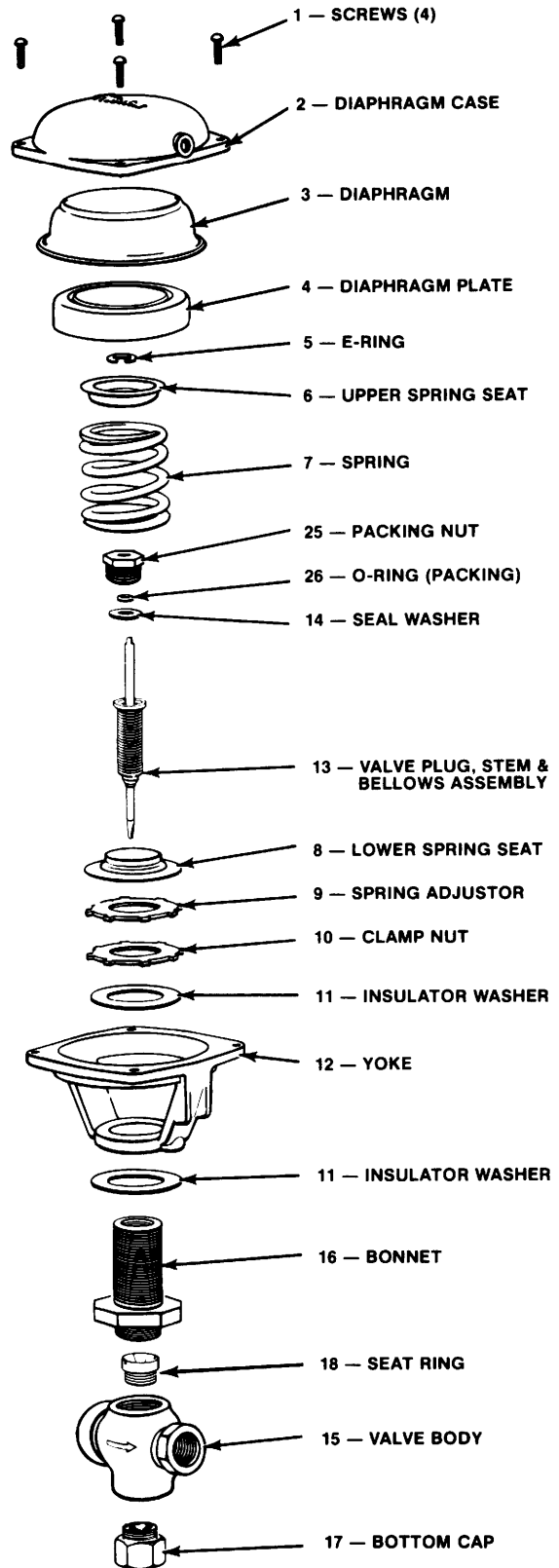

Figure 10
STYLE BH, TWO-WAY

(See Parts List Tabulations, Page 13)

VC-210 COMMON PARTS FOR ALL STYLES

Item No.	Description	Part No.
1	Screw	33715-A1509
2	Diaphragm Case	25470-A1
3*	Diaphragm	25471-D1
4	Diaphragm Plate	25472-A1
5*	E-Ring	36605-N2
6	Upper Spring Seat	25473-A1
7	Actuator Spring	See Tab. 1
8	Lower Spring Seat	25479-A1
9	Spring Adjuster	25468-A1
10	Clamp Nut	25468-A1
11	Insulator Washer (2)†	28923-A1
12	Yoke	25469-C1

† See Note 3.

TABLE 1 – DETAIL 7

Spring Span	Part No.	Bench Test (PSI)		
		Direct	Reverse	3-Way
4	25483-G1	3-13	—	4-8
4	25483-H1	—	11-15	9-13
7	25483-L1	—	8-15	—
9	25483-M1	3-12	6-15	5-14

Notes:

1. * Designates recommended spare parts.
2. Details 28, 29, 30 and 31 may be furnished as Packing Kit No. 81900-B5.
3. Style "BN" does not use insulator washer (Item 11).
4. ** Correct assembly number suffix depends on spring used (Item 7).

PARTS LIST FOR FIGURE 7, STYLES BJ, BJR, BL, BLR

Quick Opening Flow Characteristic, Styles BJ, BJR

Item No.	Valve Action/Style Size Assembly Number** (Complete Assembly)	Direct-Acting, Style BJ			Reverse-Acting, Style BJR		
		1/2"	3/4"	1"	1/2"	3/4"	1"
		81795-F1, F7	81795-F3, F9	81795-F5, F11	81725-C1, C7, C13	81725-C3, C9, C15	81725-C5, C11, C17
13*	Stem & Bellows Assy.	83614-A1	83614-A2	83614-A2	83614-A3	83614-A3	83614-A3
14	Seal Washer	25477-A1	25477-A1	25477-A1	25477-A1	25477-A1	25477-A1
15	Valve Body	25825-B1	25826-B1	33183-A1	25825-B1	25826-A1	33183-A1
16	Bonnet	33181-A1	33181-B1	33181-B1	33181-A1	33181-B1	33181-B1
17	Bottom Cap	25848-B1	7539-B1	7539-B1	25848-B1	7539-B1	7539-B1
18	Seat ring	29635-A1	33182-A1	29635-C1	29635-A1	33182-A1	29635-C1
19	Valve Plug	29633-G1	29633-H1	29633-J1	29633-G1	29633-H1	29633-J1
20*	O-Ring Seat	36240-W0111	36240-W0115	36240-W0211	36240-W0111	36240-W0115	36240-W0211
21	Retainer	29634-A1	29634-B1	29634-C1	29634-A1	29634-B1	29634-C1
23	Screw	36713-A1130	36713-A1130	36713-A1130	36713-A1130	36713-A1130	36713-A1130
24	Washer	29648-A1	29648-A1	29648-A1	29648-A1	29648-A1	29648-A1
25	Packing Nut	25478-A1	25478-A1	25478-A1	25478-A1	25478-A1	25478-A1
26*	Packing, O-Ring	36240-E0011	36240-E0011	36240-E0011	36240-E0011	36240-E0011	36240-E0011
	Repair Kits	K84420-S30	K84420-S32	K84420-S34	K84420-S60	K84420-S62	K84420-S64

Equal Percent Flow Characteristic, Style BL, BLR

Item No.	Valve Action/Style Size Assembly Number** (Complete Assembly)	Direct-Acting, Style BL			Reverse-Acting, Style BLR		
		1/2"	3/4"	1"	1/2"	3/4"	1"
		81795-F2, F8	81795-F4, F10	81795-F6, F12	81725-C2, C8, C14	81725-C4, C10, C16	81725-C6, C12, C18
13*	Stem & Bellows Assy.	83614-A1	83614-A2	83614-A2	83614-A3	83614-A3	83614-A3
14	Seal Washer	25477-A1	25477-A1	25477-A1	25477-A1	25477-A1	25477-A1
15	Valve Body	25825-B1	25826-B1	33183-A1	25825-B1	25826-B1	33183-A1
16	Bonnet	33181-A1	33181-B1	33181-B1	33181-A1	33181-B1	33181-B1
17	Bottom Cap	25848-B1	7539-B1	7539-B1	25848-B1	7539-B1	7539-B1
18	Seat Ring	29635-A1	33182-A1	29635-C1	29635-A1	33182-A1	29635-C1
19	Valve Plug	29633-D1	29633-F1	29633-A1	29633-D1	29633-F1	29633-A1
20*	O-Ring Seat	36240-W011	36240-W0115	36240-W0211	36240-W0111	36240-W0115	36240-W0211
21	Retainer	29634-A1	29634-B1	29634-C1	29634-A1	29634-B1	29634-C1
23	Screw	36713-A1130	36713-A1130	36713-A1130	36713-A1130	36713-A1130	36713-A1130
24	Washer	29648-A1	29648-A1	29648-A1	29648-A1	29648-A1	29648-A1
25	Packing Nut	25478-A1	25478-A1	25478-A1	25478-A1	25478-A1	25478-A1
26*	Packing, O-Ring	36240-E0011	36240-E0011	36240-E0011	36240-E0011	36240-E0011	36240-E0011
	Repair Kits	K-84420-S31	K-84420-S33	K-84420-S35	K-84420-S61	K-84420-S63	K-84420-S65

* See Note 1 ** See Note 4.

PARTS LIST FOR FIGURE 9, STYLE BN

Linear Flow Characteristic

Item No.	Valve Action	3-Way		
	Description	1/2" VC-210-BN	3/4" VC-210-BN	1" VC-210-BN
	Assembly Number ** (Complete Assembly)	99169-E1, E4, E5	99169-J2, J4, J5	99169-M2, M4, M5
13*	Stem, Bellows Assy	83614-A3	83614-A3	83614-A3
14	Seal Washer	25477-A1	25477-A1	25477-A1
15	Valve Body	25484-C1	25485-C1	25486-C1
16	Bonnet	33181-A1	33181-B1	25482-A3
17	Bottom Cap	25507-A1	25508-A1	25510-A1
19	Valve Plug	25497-D20	25498-A20	25499-B1
25	Packing Nut	25478-A1	25478-A1	25478-A1
26*	Packing O-Ring	36240-E0011	36240-E0011	36240-E0011
	Repair Kits	K84420-S50	K84420-S51	K84420-S52

* See Note 1 ** See note 4

PARTS LIST FOR FIGURE 10, STYLE BH

Linear Flow Characteristic

Item No.	Valve Action	Direct Acting	
	Flow Coefficient C _v	0.3	0.6
	Description	1/2" VC-210-BH	1/2" VC-210-BH
Assembly Number ** (Complete Assembly)	81795-E1, E3	91795-E2, E4	
13*	Stem, Bellows, Plug Assy	85180-A1	85180-A2
14	Seal Washer	24577-A1	25477-A1
15	Valve Body	25825-B1	25825-B1
16	Bonnet	33181-A1	33181-A1
17	Bottom Cap	25848-B1	25848-B1
18	Seat Ring	25843-A1	25843-A1
25	Packing Nut	25478-A1	25478-A1
26*	Packing, O-Ring	36240-E0011	36240-E0011

* See Note 1 ** See note 4

NOTES:

Robertshaw

Industrial Products Division

U.S.A. and Canada

Robertshaw Industrial Products Division

1602 Mustang Drive

Maryville, TN 37801

Telephone: (865) 981-3100 Fax: (865) 981-3168

<http://www.robertshaw.thomasregister.com>

<http://www.robertshawindustrial.com>

Exports

Invensys Appliance Controls

2809 Emerywood Parkway

P.O. Box 26544

Richmond, Virginia 23261-6544

Telephone: (804) 756-6500 Fax: (804) 756-6561



An Invensys company

Q-4162 (10/00)

Printed in U.S.A.