

Lockout Relay 83939-E1

GENERAL DESCRIPTION

The No. 83939-E1 Lockout Relay is a two-way, diaphragm-actuated, non-venting, normally open valve. It is used in the safety system to lock out or block certain portions of the control system or a line in a control system upon receipt of a signal at PORT 1. (See Figure 1). It will reopen with the loss of pressure at PORT 1, and has a connection which may be used to cancel the actuating pressure at PORT 1.

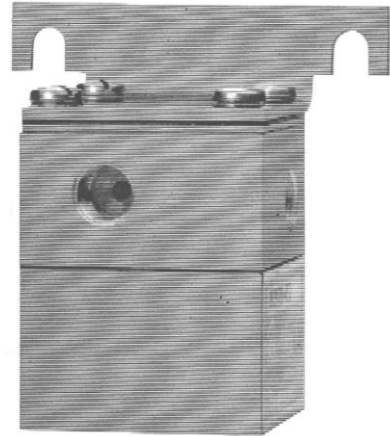

SPECIFICATIONS

Construction: Aluminum body; stainless steel cover, bracket and springs; elastomer coated fabric diaphragms and gaskets; stainless steel and aluminum valve with resilient seat.

Supply Pressure:See Figure 2.

CAUTION: DO NOT EXCEED MAXIMUM PRESSURES

Maximum Pressure:See Figure 2.

Mounting:Surface

Dimensions:See Figure 1.

Connections: 1/8"-27 NPT.

Approximate Shipping Weight: 12 ozs. (.340 kg)

Ordering Information:

Specify: No.
83939-E1

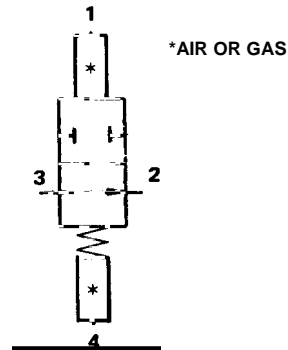

J. I. C. Symbol

INSTALLATION

A. General

Tubing and fittings used to connect the relay must be free of chips, dirt, and moisture or other foreign material.

It is recommended that an "anti-seize" type thread compound be applied to the second or third male thread in moderate amount. Do not allow compound to be deposited inside the relay. Thread sealing tape is not recommended.

For continuous, trouble-free operation, the supply to the relay must be clean and dry.

B. Mounting

When installing the No. 83939-E 1 Lockout Relay, care should be taken to prevent any foreign matter from entering the ports. Provisions should be made to prevent foreign matter from entering the ports which are left open to the atmosphere.

The relay may be installed in any position, but vertical (upright) is recommended. The relay should be securely mounted, using the two slots (clearance for No. 10 screws), provided in the mounting bracket (See Figure 1).

DIMENSIONS

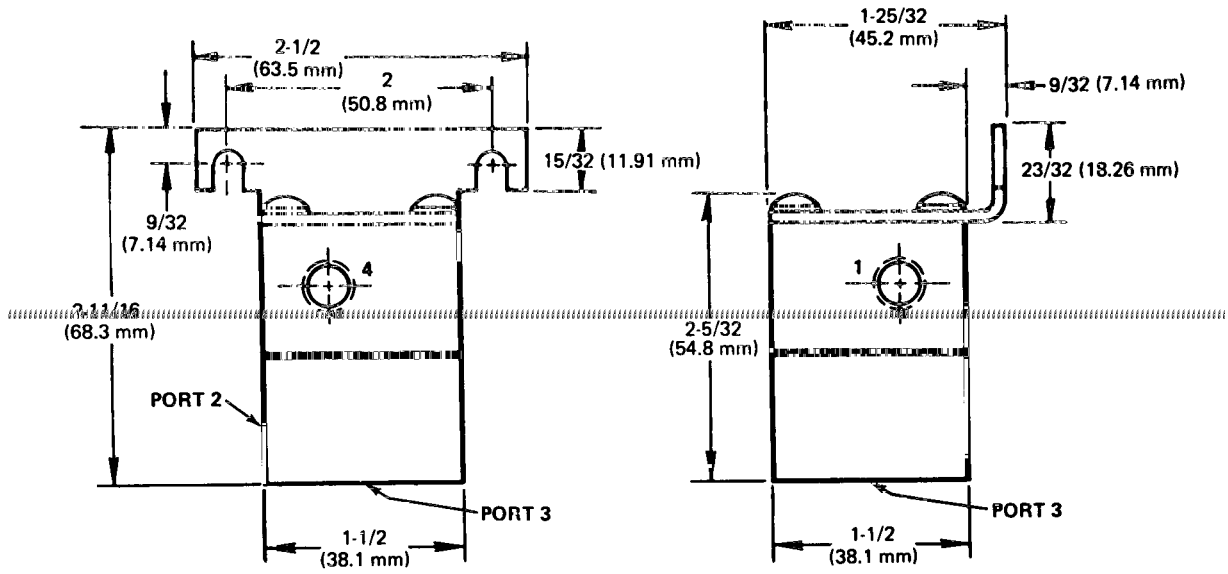

Figure 1

OPERATION (See Figure 3)

With no pressure applied to the diaphragm through Port 1, Port 3 (supply port) is connected through this normally open relay to Port 2.

When sufficient pressure is applied to the diaphragm through Port 1, the stem moves down and forces the lower poppet on seat,

closing Port 3 to Port 2. Loss of pressure through Port 1 will allow the stem to return to its original position. At the same time, the lower spring will force the lower poppet off seat, opening Port 3, again, to Port 2. Also, the relay may be reopened by applying an equalizing pressure through Port 4.

NOTE: Graph A indicates actuating pressure (Port 1) required to keep valve closed at various supply pressures (Port 3). Also, Graph A indicates actuating pressure (Port 1) minus equalizing pressure (Port 4) required to keep valve closed at various supply pressures (Port 3).

NOTE: Graph B indicates decreasing actuating pressure (Port 1) required to open valve at various supply pressures (Port 3). Also, Graph B indicates decreasing actuating pressure (Port 1) minus equalizing pressure (Port 4) required to permit same action.

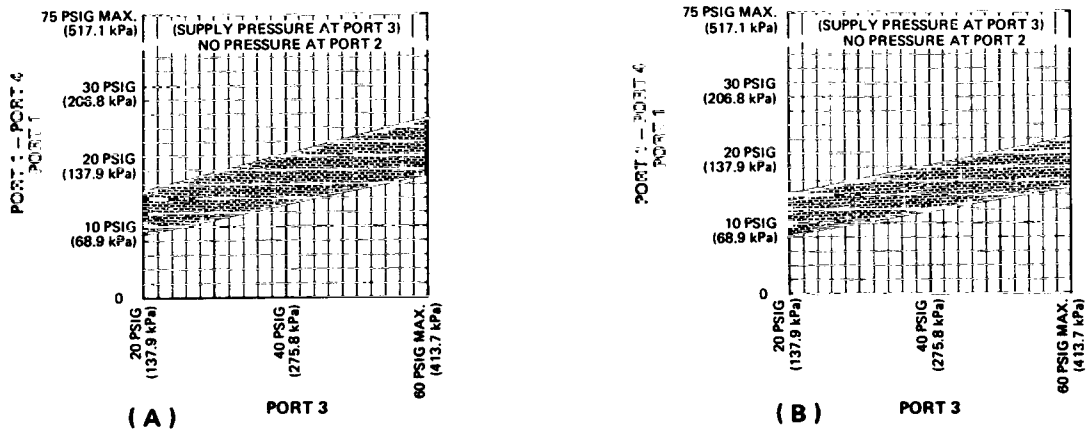

CAUTION: DO NOT EXCEED MAXIMUM PRESSURES.

Figure 2

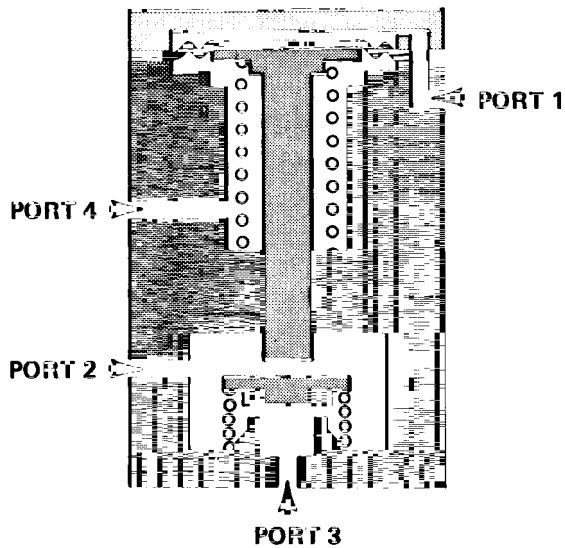

Figure 3

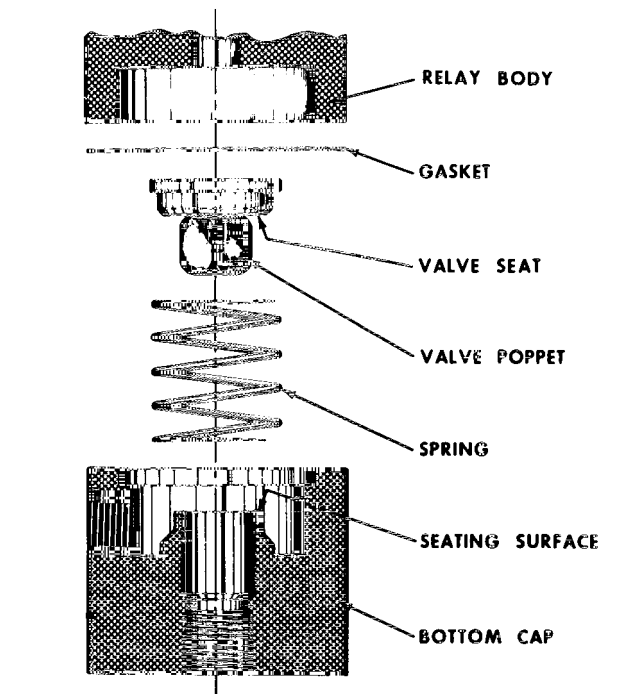

Figure 4

MAINTENANCE

WARNING: Disassemble carefully - spring load forces present.

- A. If excessive leakage occurs at valve seat, disassemble the relay. Clean poppet and seat with soft, dry cloth (See Figure 4).
- B. If relay does not function properly due to contamination by foreign matter, disassemble and clean all metal parts with non-flammable solvent and dry thoroughly.
- C. After reassembly, check for external leakage. Retighten assembly screws as necessary. Gasket cement should not be used to seal leaks due to the possibility of plugging small passages or damaging the operating characteristics of the diaphragms.

CAUTION:

If cleaning is required, do not subject "O" rings, valve poppets, diaphragms or gaskets to cleaning fluid, acetone, or any halogenated hydrocarbons such as vapor degrease liquids, etc. Clean only with a soft, dry cloth.

Upon reassembly, all "O" rings are to be lubricated with a silicone-type lubricant. Do not permit lubricant to get on poppet or valve seats.

PARTS LIST

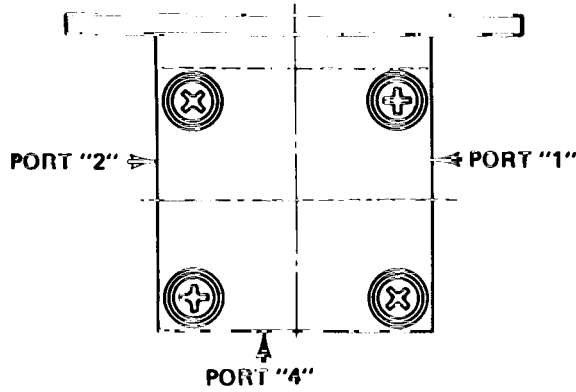

PARTS LIST

DET. NO.	NO. REQ'D	DESCRIPTION	DWG. NO.
1	4	Screw	33713-H2409
2	4	Lockwasher	36600-L0609
3	1	Mounting Bracket	24637-C2
4	1	Relay Body	31857-E1
5	1	Head & Stem Assembly	85013-81
6	1	O-Ring	36240-C10
7	1	Plug & Guide Assembly	99264-B1
8	1	Nameplate	30036-G2
9	1	Relay Body	31857-D1
10	1	Spring	25121-A1
11	2	Gasket	33665-B 1
12	1	Spring	24598-A1
13	1	Diaphragm	24498-A1
14	1	Spacer	33430-A2

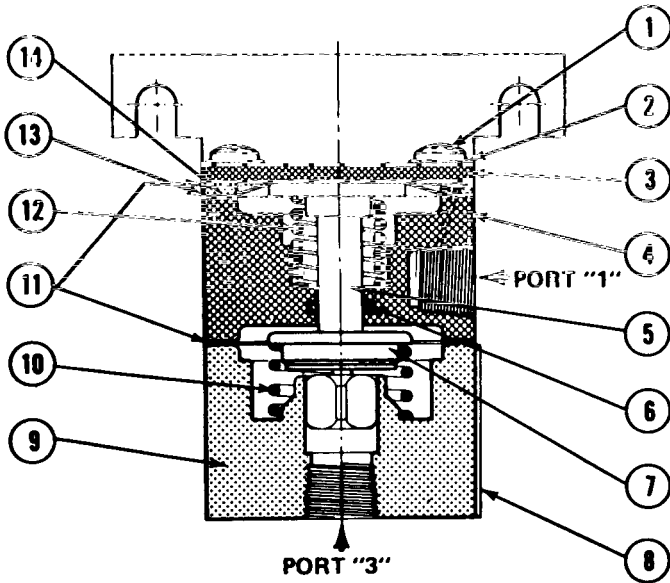

NOTE: For complete kit containing all "O" Rings, gaskets, diaphragms, and poppet to service one unit, order Repair Kit No. 82665-B3. Repair Kit includes Details 6,7,11 and 13 - also instruction manual and lubricant.

Schneider
Electric Systems USA, Inc

1602 Mustang Dr
Maryville, TN 37801
Ph (865) 981-3100
FX (865) 981-3168